

COPPER - SILVER IONIZATION SYSTEM FOR COOLING TOWERS

Eradication of bacterial, fungal and viral pathogens; reduction of chemical usage, scale and need for blow-down; this, without modifying the water parameters...

Don't be misled by unproved imitations or 'experts' not acquainted with this advanced system - H2O Biotech Ionization can deliver it!



Benefits

- Powerful bactericide and algacide
- Prevents infections of Legionella
- Plays two roles: curative and preventive (residual effect) as the ions stay in the water for weeks
- Penetrates the biofilm and acts directly at the stumps
- Effective throughout the entire water system, not just on passing water
- Not affected by temperature
- None-corrosive
- Does not destabilize water pH
- Minimal maintenance
- Compact and easy to install

Generally pays for itself within
one or two years

Which means cost saving!

- Eliminates all chemicals except corrosion inhibitor
- Reduces blow-down rate on traditional installations
- Reduces build-up of scale
- Eliminates the algae surface coating which results in better heat transfer and lower energy cost
- Extends the lifespan of the cooling tower and the coil system

And a greener environment

- Less water consumption
- Substantially reduces airborne toxic chemical drift
- Substantially reduces the risks of incidents inherent to chemical transport and handling
- Eligible for Green, LEED and Toxic release inventory points



OSHA

And others approve the use of Copper & Silver Ionization to control and prevent infections of Legionella.

HOW IT WORKS

H2O Biotech Copper - Silver Ionization Systems work by electrolysis. Electrolysis separates chemically bonded elements in electrodes by passing an electric current through them. The system consists of a reaction chamber and a control box.

- The Ionization Chamber contains up to 12 sets of electrodes made of a copper-silver alloy;
- Water flows between the electrodes and picks up electrically charged ions of copper and silver that are released through electrolysis as Cu⁺⁺ and Ag⁺;
- The Cu⁺⁺ and Ag⁺ ions freely spread out everywhere in the water system;
- Since the external membrane of algae and bacteria are negatively charged, they attract the copper and silver ions;
- Copper and silver are active against a wide range of bacteria, fungi, algae and viruses, including pathogenic organisms, such as Legionella, found as pollutants of surface water systems. The ions penetrate into them and settle on the DNA, thus entailing the total destruction of the cells;
- Depending on the complexity of the water network and the length of the standing biofilm contamination, it may take a few days or weeks for ionization to remove all traces of contaminants. However, once the system is free of all undesirable bacteria, it will remain decontaminated.

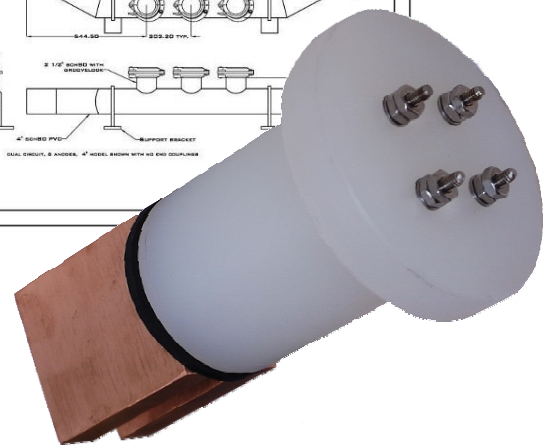
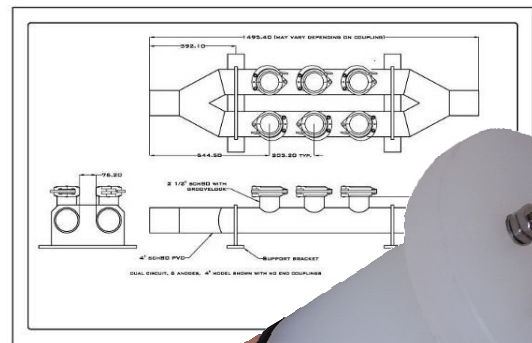

Datasheet

CONTROL BOX

Power: 110-240 VAC 50/60 Hz, 5A
Output: 0-42 VCC, max. 210W
Ripples: 300mV peak-to-peak

IONIZATION CHAMBER

Material: CPVC
Inlet/outlet: 2" or 3" (NPT, BSP, flanged...)
Maximum pressure: 130 PSI
Maximum temperature: 100°C / 210°F
Electrodes servicing: Hingelok coupling

WARRANTY

Two years for replacement of defective parts (excluding electrodes)

